

## PRODUCT TECHNICAL SHEET

### TECHNICAL DRAWING

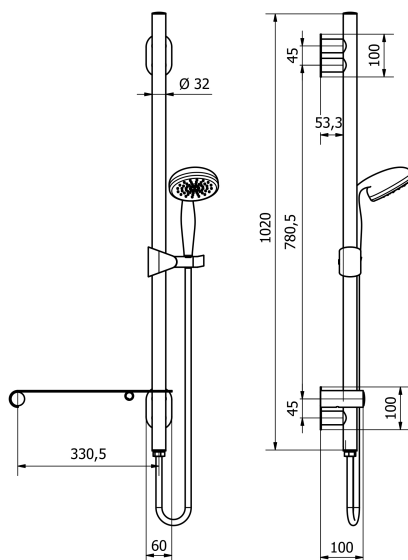

### PHOTO

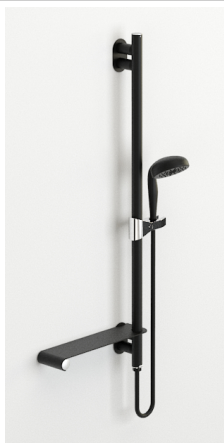

**PRODUCT FAMILY:** SHOWER COLUMN - ELEGANCE SERIES  
**CODE:** ELSHDMSXN  
**DESCRIPTION:** Safety shower column with hand shower: left shelf. Black finishes.

**MECHANICAL PERFORMANCES:**  
 Load capacity at vertical traction 200 kg.  
 Maximum flow rate: 3 bar: 10 l/min  
 Connection to water plug high or low.

### APPROVALS/CERTIFICATIONS:

### PRODUCT FEATURES:

Safety shower column mat black finish with: hand shower in ABS mat black( 3 jets ), flexible mat black and shelf in painted aluminium left position. The product is made of a column diameter 32 mm made of painted stainless steel AISI304, able to resist to a traction resistance of 200 kg. Inside the column there is a system of tubes and connections in order to conduct the water to the hand shower, in order to allow the use of water inlet 1 / 2 " G pre-existing into the wall. Taps not included in the product. It is necessary to have a mixer able to adjust the temperature and water supply.

### FIXING/INSTALLATION:

Column wall mounted with n° 2/3 fasteners  
 Fixation of the shelf with 2 fasteners  
 Connect inlet connection to the wall water intake.  
 Fasteners and screws not included in the package.  
 Choose a proper fastener, considering the type of wall on which you are going to

install the column,  
 Dimension of holes for fixing screws on the wall: Ø 10,5 mm  
 Connection for water intake ½"

### MAINTENANCE:

Check periodically the correct fixation of the accessories.  
 Make a proper cleaning with water and soap, do not use abrasive or corrosive products. Do not use for purposes that are different from intended purposes. Clean regularly the thermostatic cartridge

### PRODUCT COMPOSITION:

N° 1 Shower column made of stainless steel  
 aisi 304 - Aluminium - Brass - painted  
 N° 1 Hand shower made of white ABD N° 1  
 Flexible and components like tubes and connections

### MATERIALS:

### TREATEMENTS:

### TOLERANCES:

### PACKAGING OF THE PRODUCT:

Single package with pluriball in single carton 1500 x 110 x 120 mm.  
 Weight: 2,5 kg

The above mentioned information cannot be considered as binding. Thermomat Saniline Srl reserves the right to make technical and aesthetic changes without any prior notice.

ST\_PRODOTTO: ELSHDMSXN - 1  
 REV.00 DEL 24/01/2020

APPROVATO  
 R.T.

### THERMOMAT SANILINE SRL

Via M. Curie, 7 - 46034 Borgo Virgilio (Mantova) ITALY  
 Tel. + 39 0376 4473  
 www.thermomat.com - e-mail: info@thermomat.com

